



DRAG CHAINS

Plastic, Hybrid & Steel

HELUKABEL specializes in the manufacturing of customized plastic, hybrid and steel drag chain systems for a wide range of requirements.

In doing so, we rely on a standardized range of high-quality catalog products, which we process to create customized solutions for your individual requirements - from prototype items to large-scale production. We have an extensive range of machinery with a high degree of vertical integration

Our Strengths - Your Advantages:

- High production depth and capacity
- Competent and experienced employees
- Prototype to serial production
- Complete systems from a single source
- Reliable worldwide service

We offer our customers complete systems and assemblies with pre-assembled cables and ready-to-use drag chain systems from a single source.

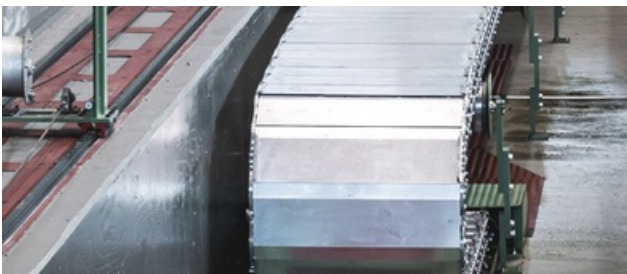

Drag chain systems are used for a wide range of applications and travel distances. HELUKABEL has the right solution for every application: from self-supporting drag chains for short distances to gliding drag chains for longer distances. Our range also includes special slide shoes to reduce wear and channel systems to guide the chains. Even for very long movement distances and high additional loads, the MARATHON system is a reliable solution



PLASTIC

Light and versatile solution for mechanical engineering. Due to their production method, these drag chains are inexpensive and quick to manufacture.

KOLIBRI Standard Drag Chain

Applications:

Handling and conveying technology, paper and textile machines

Your Advantages:

- Simple and easy opening mechanism on both sides
- Usable without connection element
- Variable interior separation
- Dividers can be quickly interchanged
- High torsional rigidity



PKK Variable Drag Chain

Applications:

Handling technology, machine tools and woodworking machines

Your Advantages:

- Locking bar for more stability with hightightening forces
- Quick and easy assembly and disassembly
- Easy to shorten and extend
- Optional multi-band solution for higher stability
- Mounting bar for larger media hoses



PFR Fully Enclosed Plastic Drag Chain

Applications:

Machine tools, welding machines, sheet metal processing, woodworking

Your Advantages:

- Protection against dirt and debris
- High-quality appearance due to closed design
- Easy to shorten and extend
- Optional metal coating to protect against hot metal chips, weld spatter or flying sparks
- Various connection options available



HYBRID

The combination of robust plastic links and aluminium stays is well-suited for large drag chain widths. The chains are available in combination with the Marathon guide channel system for long distances.

PLE Robust Drag Chain

Applications:

Machine tools, handling technology, conveyor and lifting technology

Your advantages:

- Form-fitting locking bar for highest stability
- Quick and easy assembly and disassembly of the bars
- Up to 1,000 mm bar length
- Long movement distances



GUIDE CHANNEL SYSTEM For Long Travel distances

Applications:

Indoor and outdoor crane systems, material handling, and axis 7 on robots

Your advantages:

- Aluminium and steel
- Top-hat rail mounting profile for easy alignment
- Slide rails for direct mounting
- Simple alignment due to centering pins
- Plant guide channel for uneven grounds

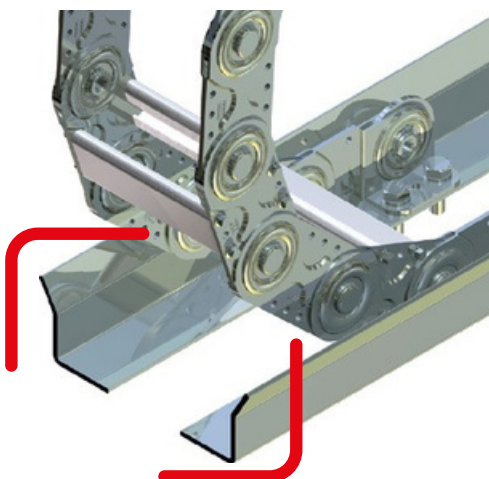

STEEL

Highest mechanical strength and temperature resistance in harsh environments.

SLE Self-supporting Drag Chain

Applications:

Machine tools, handling technology, conveyor and lifting technology, steelworks, drilling industry

Your Advantages:

- Available in steel, stainless steel and hardened versions
- Large self-supporting lengths and high filling weights possible
- Bar partitioning in many versions
- Easy to shorten and extend
- Hinge mechanism protected by cover plates



GKA Largest and Most Resilient Drag Chain

Applications:

Rolling mills, offshore plants, large machine tools

Your Advantages:

- Extra high stability
- Large self-supporting lengths up to 18 m at high cable volumes
- Variable interior design
- Bar lengths up to 1,200 mm possible
- Also available in stainless steel and customised versions

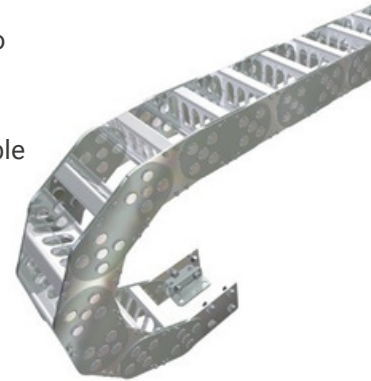

SFK Fully Enclosed Steel Drag Chain

Applications:

Machine tools and special machines with short travel distances and low number of strokes

Your Advantages:

- Closed steel jacket with retracted spring steel profile
- Large usable cross sections with small external dimensions
- Optimum cable protection
- Various connection options available
- Ideal hot metal chips, weld spatter or flying sparks

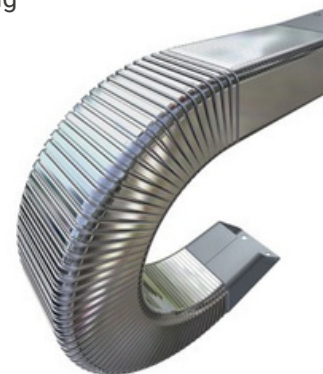



PT Helukabel Indonesia

Komplek Supitra | Jl. Pulo Kambing II No.26 | +62 21 22488299 | sales@helukabel.co.id |
www.helukabel.co.id